

SPECIFICATIONS SYSTEM SPECIFIER

www.englertinc.com

MANUFACTURER

ENGLERT, INC.
1200 Amboy Avenue
Perth Amboy, New Jersey 08861
Tel: (732) 826-8614
Fax: (732) 826-8865

SECTION 07410 - MANUFACTURED ROOF AND WALL PANELS SECTION 07610 - SHEET METAL ROOFING

PART I - GENERAL

1.01 WORK INCLUDED

Providing all labor, materials, tools, equipment and services to furnish and install metal roofing, wall panels/siding, including soffit, flashing, trim and such other accessories to make the system complete and weathertight, as indicated on the drawings and specified herein.

1.02 RELATED WORK (to be coordinated with other trades by the successful contractor under this section). FOR APPLICATIONS OVER PLYWOOD DECKING (edit as required)

- A. Section 06100: Rough Carpentry
- B. Section 06200: Finish Carpentry
- C. Section 07620: Sheet Metal Flashing and Trim
- D. Section 07700: Roof Specialties and Accessories
- E. Section 07800: Skylights
- F. Section 07900: Joint Sealers

OR

1.02 RELATED WORK (to be coordinated with other trades by the successful contractor under this section). FOR APPLICATIONS OVER METAL DECKING WITH RIGID INSULATION AND STANDING SEAM ROOF (edit as required).

- A. Section 05100: Structural Steel
- B. Section 05200: Steel Joists
- C. Section 05300: Metal Decking
- D. Section 05580: Sheet Metal Fabrication
- E. Section 07200: Insulation
- F. Section 07500: Membrane Roofing
- G. Section 07620: Sheet Metal Flashing and Trim
- H. Section 07700: Roof Specialties and Accessories
- I. Section 07800: Skylights
- J. Section 07900: Joint Sealers



This specification guide is designed to assist in the proper insertion of Englert Roof Systems into any architectural building specifications. This guide is formatted to match the CSI Spec Data System, however is not part of that program.

SERIES 1300

TRI\SPECS:1300:04/01/04
90311G

1.03 QUALITY ASSURANCE

- A. **Installation:** By a roofing/sheet metal contractor with at least a minimum of five years experience in similar type of construction and documenting successful completion of contracts for projects similar in size, scope and products.
- B. **Before Fabrication:** The contractor shall take field measurements of the structure and substrates indicated and specified to ensure that panel lengths and brakeformed flashings are dimensioned accurately to facilitate easy installation. Fabrication shall not begin until all field conditions have been verified. Allow for sufficient trimming of panel units at eaves, valleys, and gables prior to fabrication.

1.04 REFERENCES

- A. SMACNA (Sheet Metal and Air Conditioning Contractors National Association, Inc.) Architectural Sheet Metal Manual.
- B. NRCA (The National Roofing Contractors Association) Roofing and Waterproofing Manual (including Construction Details), and Handbook of Accepted Roofing Knowledge.
- C. Manufacturer's Construction Details Handbook.
- D. AISC Steel Construction Manual.
- E. AISI Cold Formed Steel Design Manual.

1.05 SUBMITTALS

- A. Submit product literature, shop drawings, and samples in accordance with Section 01340.
- B. Product Literature:
 - 1. Manufacturer's descriptive literature.
 - 2. Manufacturer's standard color chart.
- C. Shop drawings are to be a small scale layout of roof plan and elevation, indicating the extent of work to be performed. Include sections of roof, fascia, walls, siding and soffits, for each condition, detailing flashing and trim for different conditions, such as eaves, outside/inside corners, ridge, valleys, gutters, end wall terminations, closures, etc., showing a full and complete installation. Show securement of panels and dips, spacing, type and number of fasteners, as recommended by the Manufacturer.
- D. Submit 2'0" long sample panel indicating the metal, gauge, color, texture, and finish proposed.
- E. Submit Manufacturer's warranty covering the substrate (metal) against rupture, perforation, and structural failure due to normal atmospheric corrosion for twenty (25) years.
- F. Submit Manufacturer's thirty (35) year warranty on paint finish against cracking, peeling, blistering, chalk, and color change.
- G. Submit test reports complying with finish specifications per section 2.05.1 through 2.05.8.

1.06 DELIVERY, STORAGE, AND HANDLING

- A. Unload and store materials at job-site to protect them from any damage.
- B. Inspect delivered material. Prevent interference by other trades or any other adverse job conditions.
- C. Store materials above ground, on skids. Protect material with waterproof covering and allow sufficient ventilation to prevent condensation build-up or moisture entrapment in the materials.

1.07 WARRANTY

- A. Manufacturer shall warrant the metal roof against rupture or perforation or from structurally failing due to normal atmospheric conditions for a period of twenty (25) years. In addition, Manufacturer shall provide a 35-year finish warranty against peeling and blistering, chalk, and fade (color change).
- B. Installer shall provide a written warranty for two (2) years from the date of final completion and acceptance, guaranteeing materials and workmanship for watertightness, weathertightness, and against all leaks. During the initial two (2) year period, the Installer shall assure weathertightness and watertightness of the roof, without any cost to the building owner.

PART II - PRODUCTS

2.01 ACCEPTABLE MANUFACTURER

ENGLERT, INC.

1200 Amboy Avenue
Perth Amboy, New Jersey 08861
Tel: (732) 826-8614
Fax: (732) 826-8865

SERIES 1300

1" & 1-1/2" High Architectural Mechanically Locked Standing Seam

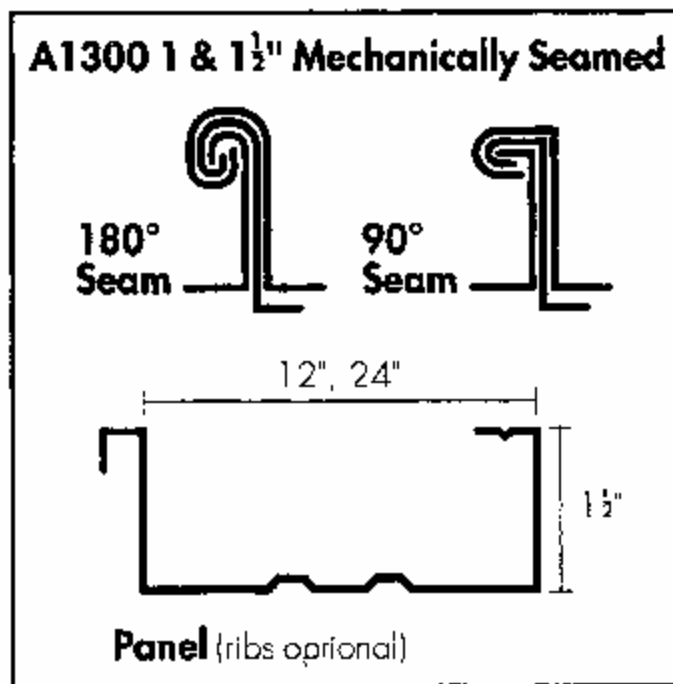

NOTE TO SPECIFIER: Englert Series 1300 Panel System serves the architectural needs of roofing/fascia, mansard, and siding systems.

The Series 1300 may be specified for application over solid deck, 1/2" plywood or 22 gauge metal deck with 2 layers of 15# felt or 1 layer of 30# felt. Minimum Pitch: 1/2"/12". Specify as required.

- A. Panel System shall be the Englert Series 1300, 1-1/2" high, 16" or 20" wide panel, Standing Seam System, (with pencil ribs and 2 mechanically seamed styles, optional), with sealant applied at the panel interlock, specify "with battens" if you wish a batten appearance. The panels shall have baked on finish as specified in Section 2.05 hereunder, in Manufacturer's standard colors. Manufacturer shall offer at least a minimum of 23 standard colors to choose from.
- B. **Substrate:**
- ? 24 Gauge baked on finish over Galvalume ASTM A-792-83, AZ50, 50 KSI yield point, 52 KSI tensile strength
 - ? * 22 Gauge baked on finish over Galvalume per ASTM A-792-83, AZ50, 50 KSI yield point, 52 KSI tensile strength.
 - ? * .032" or .040" Aluminum Alloy 3105-H14 approved equal.
- NOTE TO SPECIFIER:** *22 gauge steel, and .032" and .040" aluminum are available subject to minimum order requirements. *Call Englert for details.*
- C. **Performance:**
1. ASTM E-283-84 Air Infiltration: Maximum of 0.003 CFM/Ft.2 at 10 psf pressure differential on 180 degrees seamed profile and 0.006 CFM/Ft.2 at 20 pst pressure differential.
 2. ASTM E-331-70 Water Penetration: No evidence of uncontrolled leakage on 180 degrees seamed panel at 20 psf pressure differential.
 3. Panel shall display a flame spread classification of a (Class 1) when tested in accordance with ASTM E-84-87.
 4. Panel shall meet the requirements of UL-580, Class-90 wind uplift resistance.
 5. Panel shall be tested and conform to the requirements o the Dade County Florida non-structural roofing system criteria, product approval number must be supplied for records.
 6. Panel system shall be tested in accordance with ASTM-E-1680-95 standard test method for rate of air leakage through exterior metal roof panel systems.
 7. Panel system shall be tested in accordance with ASTM-E-1646-95 standard test method for water penetration of metal roof panel system by uniform static air pressure difference.
 8. Panel system shall be tested in accordance with ASTM-E-1592 wind uplift criteria.
*UL Classification, Construction #554, typical clip spacing for this system over 1/2" plywood is 48" o.c. at field conditions and 12" o.c. for all perimeters. Clip spacing may vary based on individual project locations, code requirements and building configurations.

IF METAL SOFFIT IS REQUIRED, SPECIFY AS FOLLOWS:

2.03 SOFFIT PANEL SYSTEMS

- A. Soffit Panels: Series 1300 is not recommended for use as a soffit system.

2.04 FABRICATION

- A. Panel Construction: Panels shall be uniformly dimensioned, rollformed to exact lengths to avoid trimming. The panel system shall be anchored as recommended by the Manufacturer. All fasteners shall be concealed. Panels shall be continuous from ridge to eaves with no end laps. There shall be no face penetration of panels, except as approved by the architect for securing panels to facilitate directional expansion/contraction.
- B. Flashing and Trim: All exposed standard or special flashing/trim and such other brakeformed in the same gauge, color, and finish to match roofing panels, furnished with protective strippable film to be removed upon installation.
- C. Accessories such as clips, closures, fasteners, etc., shall be as recommended by the Manufacturer.

2.05 PERMACOLOR 3500 FINISH - (35-Year Warranty)

- A. Englert's PermaColor 3500 standard 35-year color coatings comprises of a .8 to .9 mil full strength 70% Kynar 500 fluorocarbon (Polyvinylidene Fluoride PVF2) coating over a urethane primer of .2 to .3 mil on the finish side, with primer and a wash coat on the reverse, on steel with just a wash coat on aluminum. Face film thickness 1.0 mil \pm .2 mil.

2.05.1 FILM THICKNESS

Topside Finish: Primer shall be .2-.3 mil. Kynar 500 top coat shall be .8 - .9 mil. Reverse side finish shall be .2 - .3 mil primer with a wash coat. Total dry film thickness for the coating system shall be 1.00 mil nominal. All measurements per NCCA Technical Bulletin II-4 or ASTM D1005-84.

2.05.2 SPECULAR GLOSS

As determined per ASTM D523-85 at a glossmeter angle of 60 degrees. 10% maximum specular reflectance.

2.05.3 HUMIDITY RESISTANCE

No blistering, cracking, peeling, loss of gloss or softening of the finish after 3000 hours aluminum 1000 hours coated steel, of exposure at 100% humidity at 95 degrees F, per Federal Test Method Standard 141, Method 6201 or ASTM D2247-87.

2.05.4 SALT SPRAY RESISTANCE

Samples diagonally scored and subjected to 5% - at 95 degrees F, neutral salt spray per ASTM B117-85, then taped with Scotch #610 cellophane tape: 3000 hours aluminum/1000 hours coated steel, no blistering and no loss of adhesion greater than 1/8 from score line. (Samples taped one hour after removal form test cabinet.)

2.05.5 CHEMICAL RESISTANCE

No effect after 24 hour exposure of a 10% solution of hydrochloric acid, and 18-hour exposure to 20% sulfuric acid, per ASTM D1308-85, including exposure to 10% muriatic acid and nitric acid fumes.

2.05.6 CHALKING RESISTANCE

No chalking greater than #8 rating, per ASTM D659-86 test procedure after a 3000-hour weatherometer test.

2.05.7 COLOR CHANGE

Finish coat color change shall not exceed 5 NBS units per ASTM D-822-86, ASTM G-23-88 and ASTM D2244-85 (South Florida 10-years) test procedure after 3000-hour weatherometer test.

2.05.8 ABRASION RESISTANCE

Shall pass 60 liters/mil., minimum of falling sand per ASTM D968-81. Method A.

2.06.1 PERMAMETALLIC 2000 FINISH - (20 Year Warranty)

- A. Metallic Copper (non-aging) comprises of a .8 to .9 mil metallic fluorocarbon full strength 70% Kynar 500 finish coating over a layer of .3 to .5 mil full strength 70% Kynar 500 base coat. the reverse side is treated with a primer and wash coat. Face film thickness: 1.2 mil \pm .2 mil.
- B. Preweathered Galvalume coating comprises of a .8 to .9 mil full strength, 70% Kynar 500 fluorocarbon (Polyvinylidene Fluoride PVF2) coating over a urethane primer of .2 to .3 mil on the finish side, with primer and a wash coat on the reverse, on steel; with just a wash coat on aluminum. Face film thickness: 1.0 mil \pm .2 mil.

2.07.1 MILL FINISH GALVALUME (Bare)

- A. A coating of aluminum zinc alloy applied by a continuous hot dipping process, offering greater corrosion resistance, high temperature oxidation resistance, and heat reflectivity. Mill finish Galvalume carries a 25-year warranty (AZ-55).

PART III - EXECUTION

3.01 INSPECTION

- A. Verify substrate is uniform, even and symmetrical by running a string test. Inspect to assure that all purlins or sub-structure/framing members are flat and insulation is embedded symmetrically so when the metal panels are applied, they will not appear wavy or distorted.
- B. Provide a written report of discrepancies or variations in the substrate to the Architect.
- C. Do not begin installation until unsatisfactory conditions are corrected.
- D. Do not proceed with installation until adjoining areas scheduled for stucco treatment have been stuccoed and washed down. Do not wash down acid residues from stucco directly over the metal panels.
- E. Commencement of installation shall signify acceptance of the substrate and adjacent conditions as being proper and acceptable for treatment of roofing.
- F. After beginning installation, submit approximately 500 square feet of product in place for Architect's approval, before proceeding with substantial work.

3.02 INSTALLATION

- A. The metal panel system shall be installed plumb, level, and straight over a layer of 30 lb. felt, (dry) with a minimum 6" for horizontal lap and 12" for end lap.
- B. The (standing; batten) seam shall be equidistant and shall align for corners, hips, valleys, mullions, and columns in accordance with architectural design parameters as shown on the drawings.
- C. Installation shall be made in accordance with Manufacturer's recommended procedures and layout drawings. Manufacturer's of construction Details Handbook, SMACNA Architectural Sheet Metal manual, NRCA Roofing and Waterproofing Manual and Handbook of Roofing Knowledge shall be used as guides and details whenever applicable.
- D. No face penetrations or perforation shall be made in metal panels by fasteners without architect's specific approval. All panels shall be continuous from ridge to eaves with no horizontal end laps.
- E. End lap all flashing and trim at least 3". All gutters must be mitered, soldered and caulked with a lining of Ice and Watershield applied at the laps to make it watertight. All butt joints must be caulked. Soldered areas shall be counter-flashed or painted to match. all valleys shall be treated with a layer of Ice and Watershield spread out at least 24" each side from the center of the valley, on both sides, before applying valley flashing. End lap at least 6" at joints.
- F. Exercise proper care during installation to avoid damage or scratching of the panels. Avoid walking over the metal roof after installation is completed.

3.03 CLEANING AND PROTECTION

- A. Peel of any strippable film on flashing as they are installed.
- B. Complete all items on punch list.
- C. Touch up all minor scratches and spots.
- D. Remove all debris resulting from work under this Section.